

Paralleling TVS For Higher Power Capability

By Ivan G. Lawson

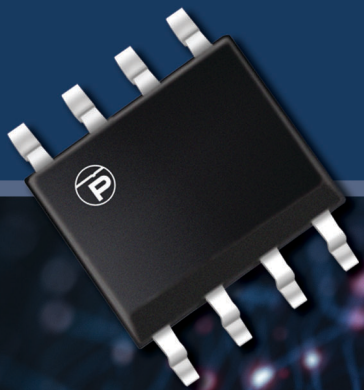

Avalanche Breakdown Diodes (TVS) offer a great deal of flexibility in circuit protection. These devices are available in voltages ranging from 2.8 Volts to 400 Volts and in power ratings from 80 Watts to 30,000 Watts. TVS devices are successfully used in higher voltage and power combinations, by configuring multiple TVS diodes in series or in parallel.

Paralleling TVS Diodes for Higher Power Capability

Power ratings for individual TVS devices are expressed in Watts, based on an industry standard pulse waveform (i.e., 10/1000µs). This waveform has a 10 ms rise time and an exponential decay to 1/2 its peak at 1000µs. Such waveforms can be derated for other pulse waveshapes, i.e., 8/20µs. Figure 1 shows a 30kW, 10/1000µs Peak Pulse Power vs Pulse Time Waveform.

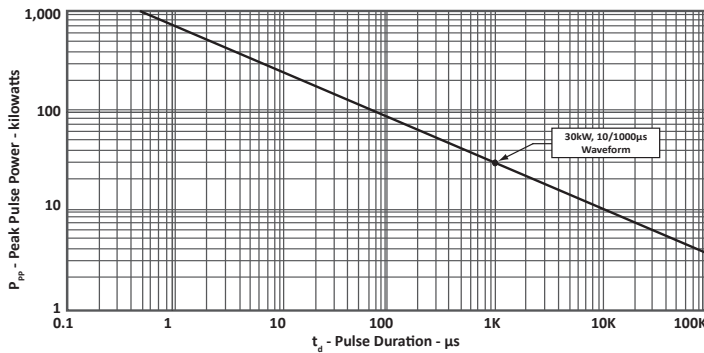

Figure 1. Peak Pulse Power vs Pulse Time

For an application in which known transient power exceeds these limits, it is possible (with appropriate cautions) to configure two or more TVS diodes in parallel. A parallel configuration will provide the same voltage response (reverse stand-off voltage and breakdown voltage) as a single unit. Leakage current will increase in proportion to the number of units paralleled.

The primary advantage in paralleling TVS diodes in this manner is increased current and power handling capability. The basic requirement is that the TVS diodes be matched in terms of clamping voltage, in order to share the transient current burden equally.

Current Sharing

Figure 2 shows a 900 Volt transient at 900 Amps divided among three TVS diodes in parallel (15KPA24A, 45V@330A power rating). 900 Amps is greater than the rated capability of a single TVS diode with the same power rating. However, by sharing the current equally, each TVS shunts 1/3 of the current (~300A), to ground. This value is within the rated capability, thus allowing the transient to be safely clamped to 40 Volts, protecting the load from damage.

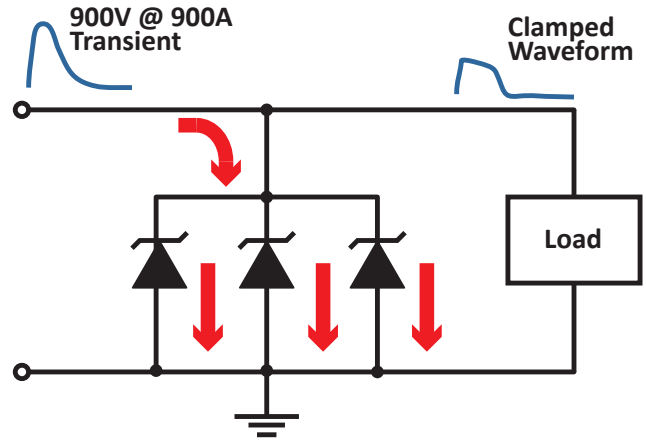

Figure 2. Three 15KPA24A in parallel.

Matching

While all three TVS devices in the above example are of the same part number, each individual unit has its own values (breakdown voltage, reverse leakage current and clamping voltage). These shifts are due to minor differences in dynamic impedance; all within the tolerances of the specification. If close attention is not paid to matching these units, the device with the lowest breakdown voltage will typically conduct first and will inadvertently handle a disproportional amount of the transient current.

The matching of the TVS diodes on the basis of clamping voltage under pulse conditions at moderate current levels is recommended. Rather than measuring low current breakdown voltages only, this method provides accurate voltage matching by taking into account the dynamic effects under higher currents.

Each device is subjected to a known pulse level, such as a 1 Amp, 1ms rectangular pulse. Clamping voltage is then monitored by a peak reading voltmeter with sufficiently fast response. Units can then be sorted into groups of 1% tolerance for best current sharing performance profiles. It is also recommended that lead lengths and circuit board traces in the shunt path of the board layout, be as short as possible. Through proper selection and configuration, an effective TVS combination can be achieved for almost any protection need.

COMPANY PROFILE

In business more than 30 years, ProTek Devices™ is a privately held semiconductor company. The company offers a product line of overvoltage protection components. These include Transient Voltage Suppressor arrays (TVS arrays), Steering Diode/Hybrid arrays, Thyristor Surge Suppressors, EMI Filters, High-Powered Components and Modules as well as Chipscale TVS arrays. These devices deliver circuit protection in electronic systems from numerous overvoltage events. They include lightning; electrostatic discharge (ESD); nuclear electromagnetic pulses (NEMP); inductive switching; and electromagnetic interference (EMI) / radio frequency interference (RFI). ProTek Devices is an ISO 9001 certified company.

CONTACT US

Corporate Headquarters

2929 South Fair Lane
Tempe, Arizona 85282
USA

By Telephone

General: 602-431-8101
Sales: & Marketing: 602-414-5109
Customer Service: 602-414-5114
Product Technical Support: 602-414-5107

By Fax

General: 602-431-2288

By E-mail:

Asia Sales: asiasales@protekdevices.com
Europe Sales: europesales@protekdevices.com
U.S. Sales: ussales@protekdevices.com
Distributor Sales: distysales@protekdevices.com
Customer Service: service@protekdevices.com
Technical Support: support@protekdevices.com

ProTek Devices (Asia Pacific) Pte. Ltd.

8 Ubi Road 2, #06-19
Zervex
Singapore - 408538
Tel: +65-67488312
Fax: +65-67488313

Web

www.protekdevices.com

COPYRIGHT © ProTek Devices 2022 - This literature is subject to all applicable copyright laws and is not for resale in any manner.

SPECIFICATIONS: ProTek reserves the right to change the electrical and or mechanical characteristics described herein without notice.

DESIGN CHANGES: ProTek reserves the right to discontinue product lines without notice and that the final judgement concerning selection and specifications is the buyer's and that in furnishing engineering and technical assistance. ProTek assumes no responsibility with respect to the selection or specifications of such products. ProTek makes no warranty, representation or guarantee regarding the suitability of its products for any particular purpose, nor does ProTek assume any liability arising out of the application or use of any product or circuit and specifically disclaims any and all liability without limitation special, consequential or incidental damages.

LIFE SUPPORT POLICY: ProTek Devices products are not authorized for use in life support systems without written consent from the factory.